

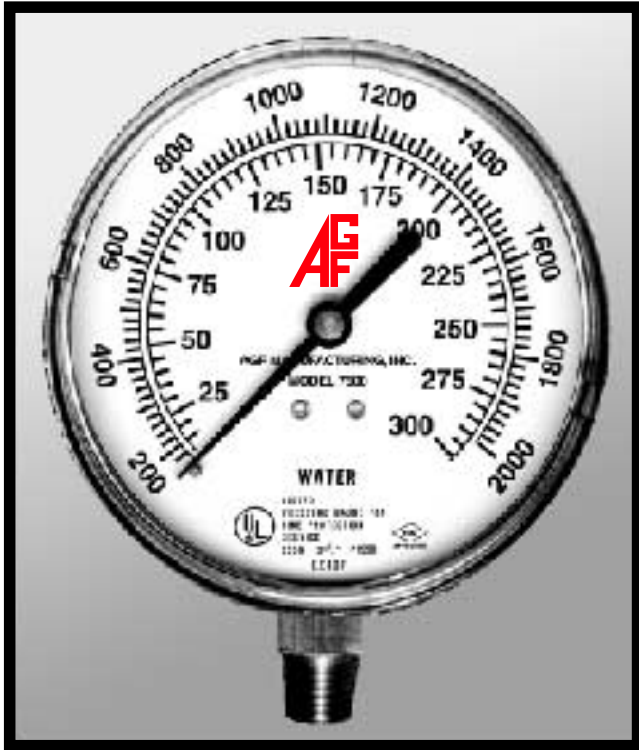

MODEL 7500

PRESSURE GAUGE **FOR FIRE SPRINKLER SYSTEMS**



The AGF Manufacturing, Inc. **Model 7500** Pressure Gauge is a Factory Mutual Approved and Underwriters Laboratory Listed 3 1/2" gauge designed for use on "wet" sprinkler systems. The AGF **Model 7500** has been designed to meet NFPA System Attachments requirements as specified in NFPA 13 Sec. 4-7.3. The **Model 7500** fulfills the installation specifications for a pressure gauge as stipulated in NFPA 13 Sec. 3-1.1, 3-7.7, 4-6.1.2.2, NFPA 13D Sec. 3-2, and NFPA 13R Sec. 2-4.3.

SPECIFICATIONS

- | | |
|--|--|
| <p>RANGE
0-300 psi (inside)
0-2000 Kpa (outside)</p> <p>ACCURACY
±3-2-3%</p> <p>BURDON TUBE
Phosphor Bronze</p> <p>WINDOW
Polycarbonate one-piece ring and crystal</p> | <p>DIAL
Galvalume</p> <p>POINTER
Aluminum, painted black</p> <p>CASE
PGE Xenoy® DX2735</p> <p>CONNECTION
Brass, 1/4" ANPT LM</p> |
|--|--|



MODEL 7600

**1/4" 3-WAY
GLOBE VALVE**

**NFPA 13
SEC. 5-15.3.1.**

...EACH GAUGE
CONNECTION SHALL BE
EQUIPPED WITH A
SHUTOFF VALVE AND
PROVISION FOR
DRAINING.

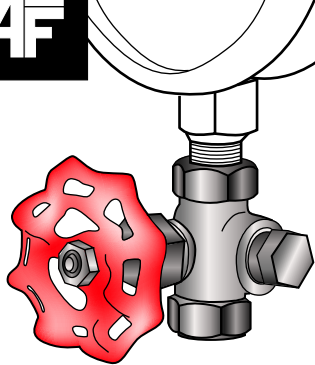
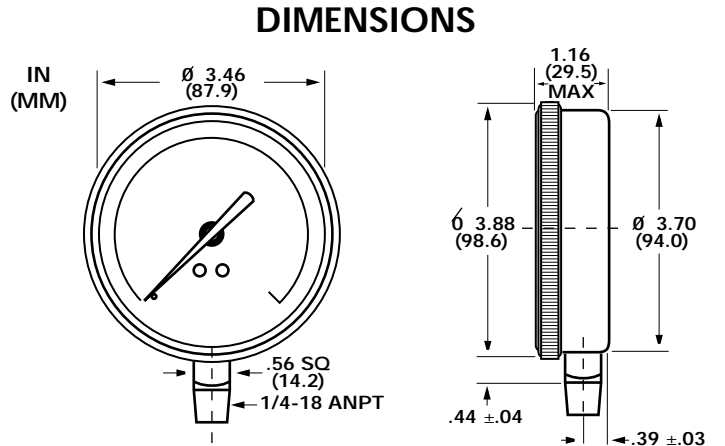
AGF Manufacturing, Inc. provides many different products to address a variety of job conditions. Please contact our office for advice and products modified to solve specific job conditions. Thank you for using our products.

Check Out Our AutoCAD Site!
Visit us on the Internet at
www.testandrain.com

AGF MANUFACTURING INC.
100 Quaker Lane
Malvern, PA 19355 USA
Telephone: (610) 240-4900
Fax: (610) 240-4906
www.testandrain.com

JOB NAME: _____
ARCHITECT: _____
ENGINEER: _____
CONTRACTOR: _____